

Constructing a Model of ppbv of Surface Ozone



Welcome

Introduction

Protocols

Learning Activities

Appendix

Purpose

To construct a model that will provide students with a visual representation of parts per billion by volume of surface ozone in the air

Overview

Students will work in teams to construct cubes of different volumes and to compare them to get a feel for parts per million by volume and parts per billion by volume.

Student Outcomes

Students gain a feeling for the small quantities of gases, such as ozone, present in the Earth's atmosphere.

Science Concepts

Earth and Space Science

The atmosphere is made up of different gases and aerosols.

Atmosphere Enrichment

The concentration of surface ozone in the atmosphere is variable.

General

Scale models help us understand concepts.

Scientific Inquiry Abilities

Identify answerable questions.

Use appropriate tools and techniques.

Use appropriate mathematics to analyze data.

Develop and construct models using evidence.

Communicate procedures and explanations.

Time

Two to three class periods

Level

Middle and Secondary

Materials and Tools

Copies of cubic patterns to construct

Scissors

Clear tape

Metric rulers marked in mm

Meter sticks

Clear tape

Centimeter blocks to form cubes of different sizes

Model of Cubic Meter-Oaktag or cardboard with cm cube pattern, dowels, corner pieces, and tape or Velcro

Preparation

Copy sheets with patterns for students to construct models of different sized centimeter cubes.

Construct and display a model of one cubic meter.

Prerequisites

Ability to accurately measure in mm, cm, m

Ability to calculate the area of rectangle



Introduction

Scientists in every scientific field construct models to picture things that they cannot directly observe. Examples of such models are scale models of the solar system or of molecules and atoms. This activity focuses on constructing a model of chemical mixing ratios in parts per million by volume and parts per billion by volume. In *Hydrology*, the learning activity *Modeling Your Watershed* is another example of constructing a physical model to help understand the environment.

Student educational experiences may vary, so some instruction may be required to understand a model of parts per billion by volume (ppbv). The first activity is designed to provide a hands-on exploration of cubic centimeters and to teach students how the volume of a cube is calculated. It starts with a very basic model, in which students can directly see and count the component parts. The activity moves to a model in which some of the components are hidden and must be inferred or the model dismantled to reveal the components inside in order to determine the volume. This initial activity provides a common foundation from which a group of students may explore more complex cubic models of volume. Centimeter blocks may be used to demonstrate the volume of different sized cubes. In the event none are available, a pattern with directions for constructing cardboard models has been provided in the Appendix.

Students enter a classroom with varied mathematical backgrounds. To develop a common level of understanding, students may be introduced to cubic volume beginning with cubes having a height (h), width (w) and depth (d) of one centimeter. This will develop the rudimentary concept of a cubic centimeter as one unit.

What To Do and How To Do It

Ask the class if they know what a part per billion is. Allow for a brief discussion, but expect this concept to be new to students.

Have each team look at a one cm cube. Ask the students to measure and record the length, width and height of their cube. Define for the students that a cube with the dimensions 1 cm x 1 cm x 1 cm has a volume of 1 cubic centimeter, which can be written as 1 cm^3 (or 1 cc).

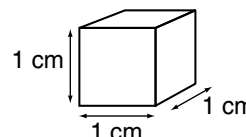

Have the groups of students assemble a cube 2 cm x 2 cm x 2 cm. Ask them to determine the volume of this cube. Ask them to identify whether they counted, added, or multiplied to get their answer and let them briefly discuss their choices.

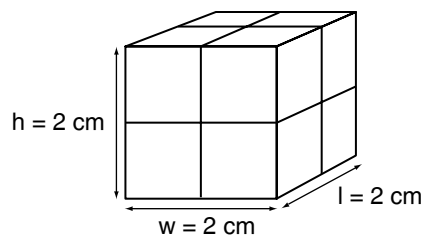

Have the groups of students assemble a cube 3 cm x 3 cm x 3 cm. Ask them to determine the volume of this cube. Ask them to identify whether they counted, added, or multiplied to get their answer, and let them briefly discuss their choices. Ask them if they would be willing to count or add to get the volume of a much larger cube.

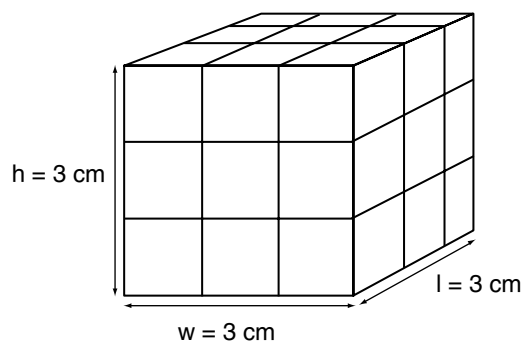

Have the groups of students assemble a 5 cm x 5 cm x 5 cm cube. Ask them to determine the volume of this cube. Ask each group how they got the volume of their cube. The volume equals 125 cubic centimeters or 125 cm³.

How many blocks within the cube can you see?

How many cubes do you think are not visible, but you know are inside the cube?

How can you calculate the volume of this cube?

How can you prove that your calculation of the volume of this cube is correct?

Introduce the cubic meter model. Have each group place a single one-cubic-centimeter cube on the cubic meter.

How many one cubic centimeter cubes does it take to fill a cubic meter? Answer: (1 million)

Explain to the students that the cube (one cubic centimeter) is one part per million by volume of the cubic meter.

Give the students a one-cubic-millimeter cube cut from cardboard. Have them place it in one of the cm cubes marked on the cubic meter.

How many one cubic millimeter cubes will it take to fill a cubic centimeter? Answer (1 thousand)

How many to fill a cubic meter? Answer (1 billion)

Explain that this means that the 1 mm cube is one part per billion by volume of the cubic meter.

Inform the students that they will be (or are) measuring ozone concentrations of parts per billion by volume, and have the students discuss in their groups how one part per billion of a cubic

Cubic Meter

$1\text{ m} \times 1\text{ m} \times 1\text{ m} = 1\text{ cubic meter or } 1\text{ m}^3$

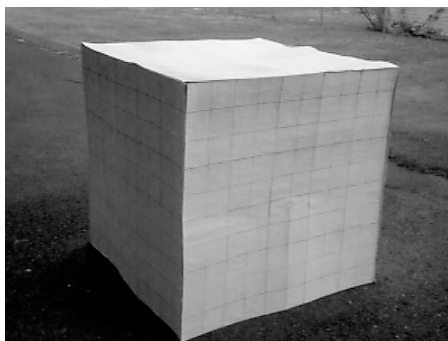

meter relates to the concentration of ozone that they will be measuring. Have the groups share their ideas with the class.

Student Sheet

The student sheet shows the steps to follow to determine the volume of a cube. These directions follow those in the *What To Do and How To Do It* section of the teacher's lesson plan. The students will need the cubic meter to complete the challenge section of the student sheet.

Extension Activity

In this extension of the ppb activity, students will represent the amount of ozone they measure in the atmosphere as a portion of the total volume of their classroom.

Materials

- Model of one cubic meter set up in classroom
- One set of metric blocks per team or copies of the patterns on thin cardboard
- Ozone data from your school or another local source such as a GLOBE school or a newspaper article
- Scissors and glue, to enable each team to make their own models for problem solving
- Student sheets to review and complete as a team after the lesson is introduced

Student Preparation

Organize the class in teams of 3-4 students and have each team decide who will be the recorder, facilitator, engineer and reporter. If possible, each student should be given the chance to play each role.

Provide each team facilitator with copies of the student sheets for each team member.

Provide each engineer with the materials and directions needed to construct models and to complete the problem-solving activities.

Recorder- takes notes for the team

Facilitator- gets the directions the team will be following and makes sure that everyone on the team understands the directions. This person also encourages all team



members to share ideas and be involved in the processes used by the team.

Engineer- gets the materials and guides the construction of models.

Reporter- the spokesperson for the team and presents the team's work to the whole class.



What To Do and How To Do It

Have the students measure and calculate the volume of their classroom in cubic meters. Then, have them determine how many cubic millimeters they would need to physically represent the concentration of ozone in ppb they measured outside.

Procedure:

1. Measure the length, width, and height of the classroom in meters. Multiply the length x width x height to determine the total cubic meters of air in the classroom
2. Make a model of the parts per billion of surface ozone measured outside during that day for each cubic meter of air identified in the classroom. This is done by multiplying the amount of surface ozone in ppb outside by the number of cubic meters in the classroom.
3. Hang the parts per billion of ozone measured for each cubic meter of air in the classroom. This model will demonstrate the amount of ozone that would exist in a volume of atmosphere the size of the classroom. If you are not yet collecting ozone data, look up a daily ozone measurement for a nearby GLOBE school or look in the newspaper for a local ozone value.

Example: Students have measured 20 ppbv as the concentration of ozone. The classroom is 6 meters wide by 9 meters long by 3 meters high for a volume of $6 \times 9 \times 3 = 162 \text{ m}^3$. 20 billionths of this volume is $3,240 \text{ mm}^3$ or 3.24 cm^3 . So to represent the amount of



ozone measured, the students would hang 3 cubic centimeter cubes and 240 cubic millimeter cubes or 3,240 cubic millimeter cubes. As an alternative, students could construct 20 cubes scaled to be 1 billionth the volume of the classroom (i.e., 6 mm x 9 mm x 3 mm).

Student Assessment

Rubric for assessing GLOBE Student Science Log

Checklist for team collaboration

Science Log Question: *You have been asked to explain your surface ozone measurement of 55 ppbv. Write a description of ppbv that will explain the measurement and give a visual image of how much a ppbv represents in the atmosphere.*

The sample rubric may be used to assess the student's response in the journal. It is assessed after students have shared and had time to add changes in their thinking as a result of their discussions. Provide the students with a copy of the sample rubric (or another model you may develop with the students to define the criteria for assessing their response.

Helpful Hints

Monitor team discussions and help them clarify points as they work through the above activities.

Frequently Asked Questions

1. What is a safe level of surface ozone for us to breathe?

The U.S. Environmental Protection Agency has established as unhealthy an ozone concentration that exceeds 80 ppbv for eight hours or more.

2. Is there as much surface ozone inside our classroom as there is outside?

No, surface ozone would be more concentrated outside than inside the classroom. It is destroyed when it comes in contact with the building and other objects outside.

1 cubic mm



1 cubic cm = 1000 cubic mm
(10 x 10 x 10 mm)

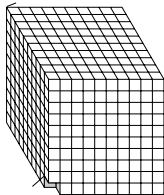

1000 cubic cm = 1,000,000 cubic mm
(100 x 100 x 100 mm)

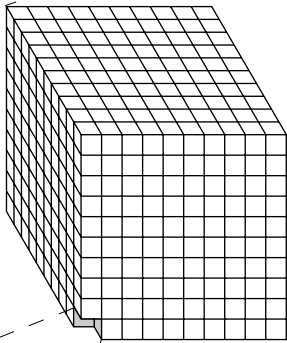

1 cubic meter = 1,000,000 cubic cm (100 x 100 x 100 cm)
OR **1,000,000,000 cubic mm (1000 x 1000 x 1000 mm)**

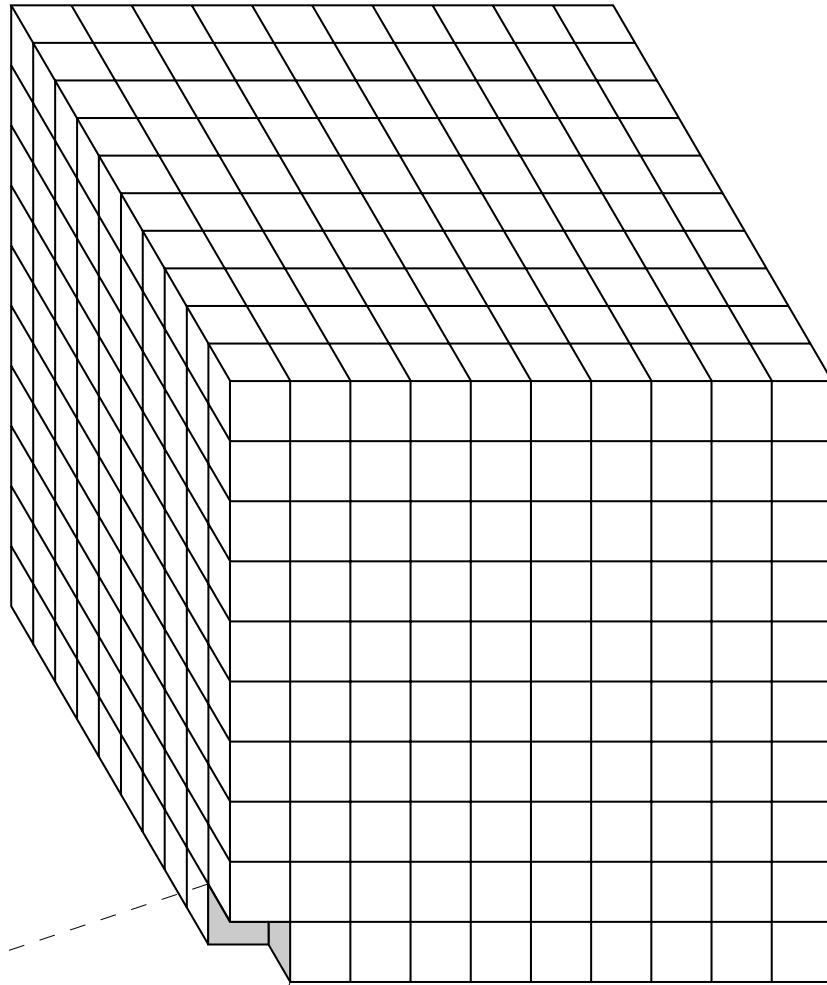

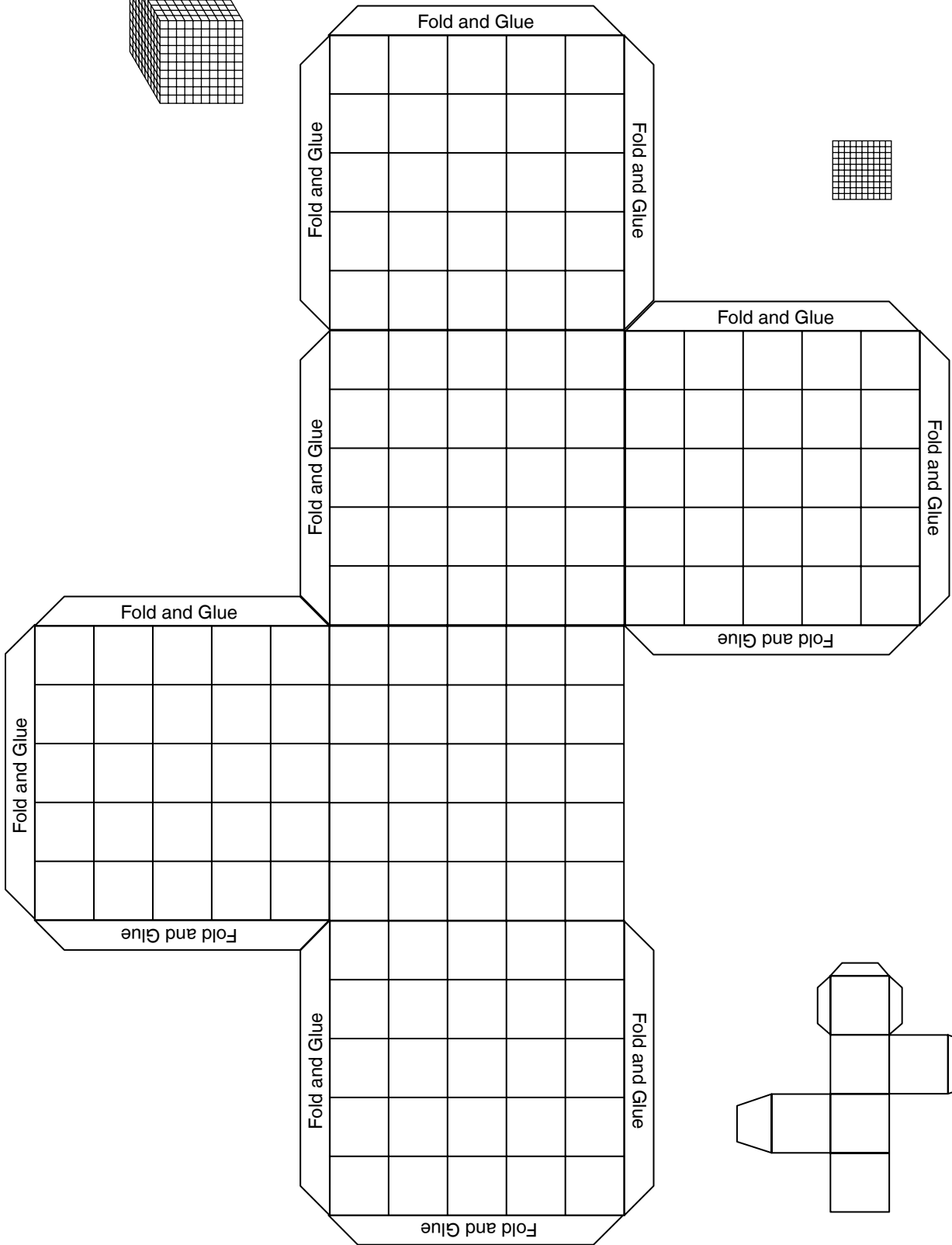
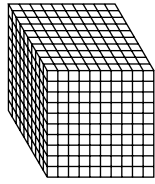

Constructing a Model of ppbv of Surface Ozone

Work Sheet

1. Look at the small cube. What is the length (l), width (w), and height (h) of the cube?

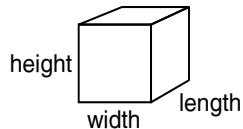

length = _____

width = _____

height = _____

One cubic centimeter is written _____

2. Make a 2 cm x 2 cm x 2 cm cube.

- Determine the volume of your cube.
- Tell how you determined the volume of your cube.

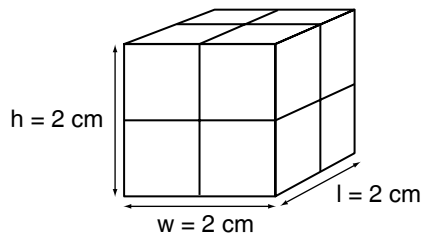

3. Make a 3 cm x 3 cm x 3 cm cube.

- Identify the volume of this cube.
- Tell how you determined the volume of your cube.

Volume (V) = _____ cm³

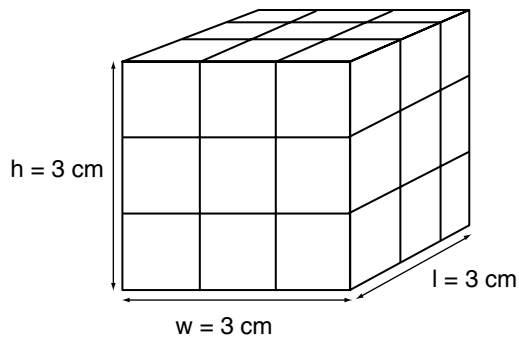

4. Build this cube and i
you find the volume

$V = \text{_____ cm}^3$

$h = \text{_____ cm}$

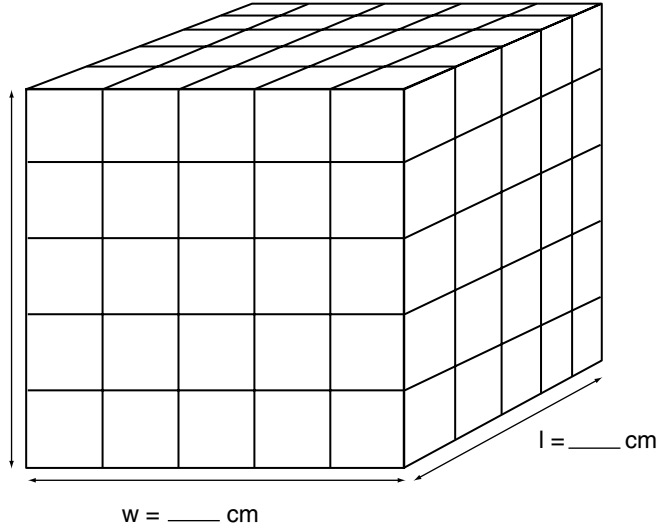

5. a. How many of the above cubes would fit into this cube? _____
b. What is the volume of this cube? _____ cm^3
c. Identify how you found the volume of this cube.

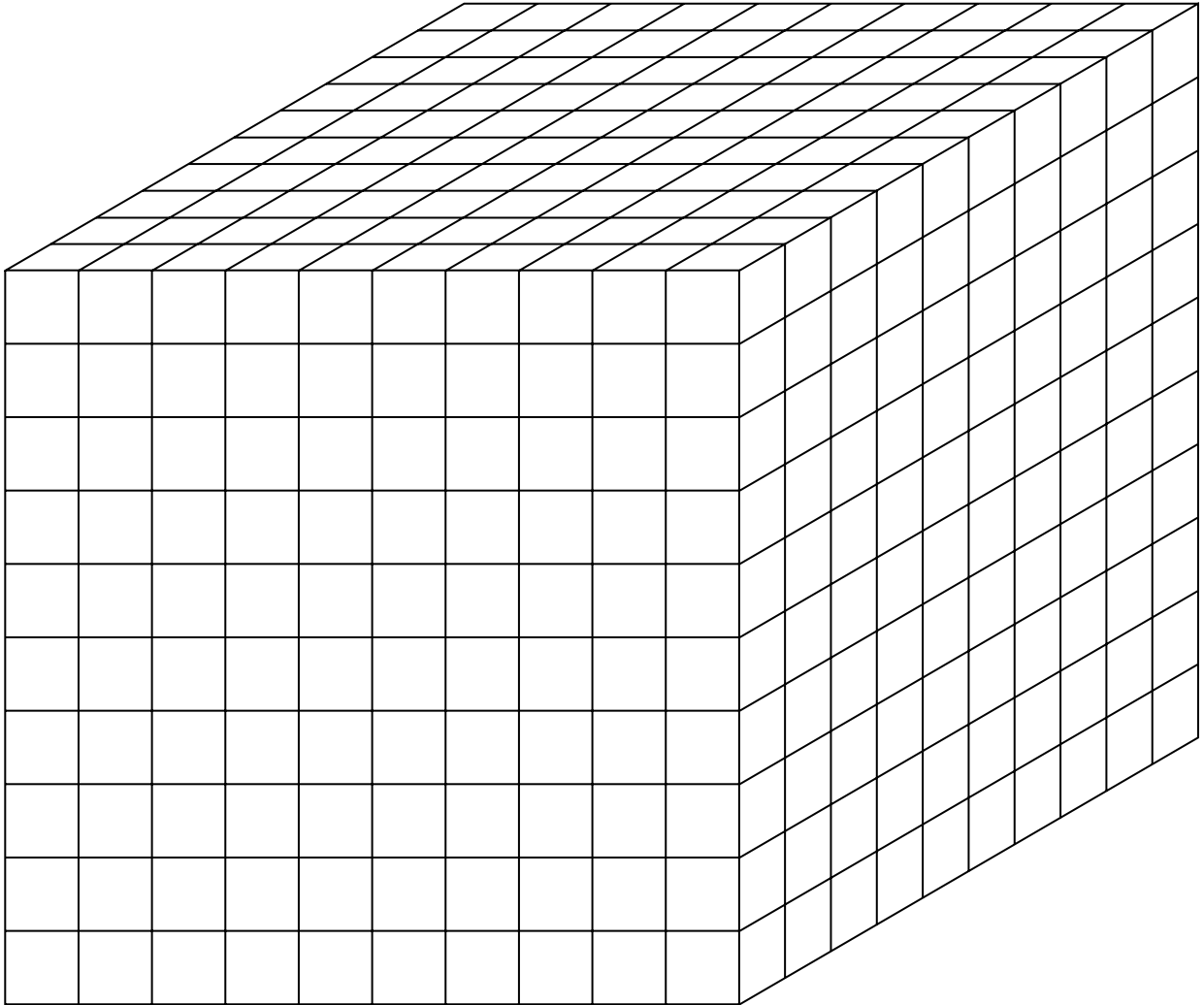

The Challenge

Work with your team to solve the following problems. Record the steps you use to solve your problems in the space below each question.

1. How many cubic centimeters fit into a cubic meter?

2. How many cubic millimeters fit in a cubic meter?

3. What is the volume of a cube that is 1 part per million by volume in a cubic meter?

4. What is the volume of a cube that is 1 part per billion in a cubic meter?
